



TIG200/TIG200P

TIG200PFC /TIG200P PFC

IGBT INVERTER WELDER

Thank you for selecting this new JASIC equipment!

This operating manual contains important information on the use and maintenance of this product, as well as safe handling of the product. Please refer to technical parameters of the equipment in Technical Parameter section in this manual, and read the manual carefully before using the equipment for the first time. For your own safety and that of your working environment, please pay particular attention to the safety instructions in the manual and operate the equipment according to the instructions. For more information on JASIC products, please contact JASIC Technology, consult an authorized JASIC dealer or visit JASIC website at www.jasitech.com.

Disclaimer

Shenzhen JASIC Technology Co., Ltd. solemnly promises that this product is manufactured according to relevant domestic and international standards, and that this product conforms to EN60974-1 International Safety Standard. Patents protect the relevant design scheme and manufacturing technology adopted in this product.

1. Whilst every effort has been made to ensure that the information contained within this manual is complete and accurate, no liability can be accepted for any errors or omissions. Please note products are subject to continual development and may be subject to change without notice.
2. Though contents in this manual have been carefully checked, there may be inaccuracies. Please do not hesitate to contact us in case of any inaccuracy.
3. Do not copy, record, reproduce or transmit the contents of this manual without prior permission from JASIC.

Manufacturer: Shenzhen JASIC Technology Co., Ltd.

Registered Trademark: JASIC

Registered Address: No.3 Qinglan 1st Road, Pingshan District, Shenzhen, Guangdong, China

Postcode: 518118

Tel:+86 (0755) 8670 6250

Website: www.jasitech.com

Fax: +86 (0755) 27364108

E-mail: sales@jasitech.com

Contents

1. Safety precautions	5
1.1. General safety	5
1.2. Other precautions	8
2. Description of symbols.....	9
3. Product overview	12
4. Technical parameters.....	13
5. Installation	16
5.1. External interface description	16
5.2. Power installation.....	17
5.3. MMA electrode holder and earth cable connection	18
5.4. TIG welding torch and earth cable connection.....	19
5.5. Wired handheld remote controller connection (optional).....	20
5.6. Installation of wireless receiver module (optional)	20
6. Control panel	21
6.1. TIG200/TIG200PFC HD digital panel	21
6.2. TIG200P/TIG200P PFC HD digital panel.....	28
6.3. Other functions	30
7. Welding function operation	34
7.1. MMA operation	34
7.2. DC TIG operation.....	37
7.3 DC pulse TIG operation	41
8. Maintenance	44
8.1. Power supply maintenance.....	44
8.2. Welding torch maintenance	44
9. Troubleshooting	46
9.1. Common malfunction analysis and solution.....	46
9.2. Alarms and solutions.....	49
10. Packaging, transportation, storage and waste disposal.....	50
10.1. Transportation requirements.....	50
10.2. Storage conditions	50
10.3. Waste disposal	50
Appendix 1: Wiring diagram of TIG200P PFC/TIG200PFC	51
Appendix 2: Wiring diagram of TIG200P/TIG200	52
Appendix 3: List of common spare parts.....	53

For your safety, please read this manual carefully before installing and operating this JASIC equipment.

Pay extra attention to all content marked with "  ".

All operations must be carried out by professional, suitably qualified persons!

1. Safety precautions

1.1. General safety



SAFETY INSTRUCTION

These general safety norms cover both arc welding machines and plasma cutting machines unless otherwise noted.

It is important that users of this equipment protect yourselves and others from harm or even death.

The equipment must only be used for the purpose it was designed for. Using it in any other way could result in damage or injury and in breach of the safety rules.





Only suitably trained and competent persons should use the equipment.



Pacemaker wearers should consult your doctor prior to using this equipment

PPE and workplace safety equipment must be compatible for the application of work involved.

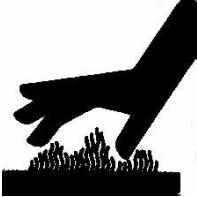
Always carry out a risk assessment before carrying out any welding or cutting activity

	<p>Only qualified personnel should operate this machine!</p> <ul style="list-style-type: none"> · Always use the appropriate personal protective equipment. · Always pay attention to the safety of other persons around the welding zone · Do not carry out any maintenance with the power on the machine
	<p>Electric shock—May cause serious injury or even death!</p> <ul style="list-style-type: none"> · The equipment should be installed by a qualified person and in accordance with current standards in operation. It is the user's responsibility to ensure that the equipment is connected to a suitable power supply. Consult with your utility supplier if required. Do not use the equipment with the covers removed. · Do not touch live electrical parts or parts, which are electrically charged. · Turn off all equipment when not in use.
	<p>Fumes and gases—May be hazardous to your health.</p> <p>Locate the equipment in a well-ventilated position and keep your head out of the welding fume.</p> <p>Do not breathe the welding fume.</p> <p>Ensure the welding zone is well ventilated and provision should be made for suitable local fume extraction system to be in place.</p> <p>If ventilation is poor, wear an approved air fed welding helmet or respirator.</p> <p>Read and understand the Material Safety Data Sheets (MSDS's) and the manufacturer's instructions for metals, consumable, coatings, cleaners and de-greasers.</p> <p>Do not weld in locations near any de-greasing, cleaning or spraying operations.</p> <p>Be aware that heat and rays of the arc can react with vapours to form highly toxic and irritating gases.</p>

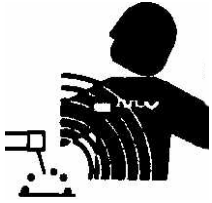
	<p>Arc rays—May injure the eyes and burn the skin.</p> <p>Welding arc rays from all welding processes produce intense, visible and invisible (ultraviolet and infrared) rays that can burn eyes and skin.</p> <ul style="list-style-type: none"> ·Wear an approved welding helmet fitted with an appropriate shade of filter lens to protect your face and eyes when welding or watching. ·Wear approved safety glasses with side shields under your helmet. ·Never use broken or faulty welding helmets. ·Always ensure there are adequate protective screens or barriers to protect others from flash, glare and sparks from the welding area. ·Ensure that there are adequate warnings that welding or cutting is taking place. ·Wear suitable protective flame resistant clothing, gloves and footwear.
	<p>Precautions against fire and explosion</p> <p>Avoid causing fires due to sparks and hot waste or molten metal.</p> <p>Ensure that appropriate fire safety devices are available near the welding and cutting area.</p> <p>Remove all flammable and combustible materials from the welding, cutting and surrounding areas.</p> <p>Do not weld or cut fuel and lubricant containers, even if empty. These must be carefully cleaned before they can be welded or cut.</p> <p>Always allow the welded or cut material to cool before touching it or placing it in contact with combustible or flammable material.</p> <p>Do not work in atmospheres with high concentrations of combustible fumes, flammable gases and dust.</p> <p>Always check the work area half an hour after cutting to make sure that no fires have begun.</p> <p>Take care to avoid accidental contact of electrode to metal objects. This could cause arcs, explosion, overheating or fire.</p>
	<p>Risks due to hot material ·</p> <p>The welding process will create hot metal, sparks and drips of molten metal, so it's very important to ensure the operator is equipped with full PPE and to always ensure there are adequate protective screens or barriers to protect others from flash, glare and sparks from the welding area. Hot surfaces will create fires and will burn any exposed skin.</p> <p>Always protect your eyes and body. Use the correct welding screen and filter lens and wear full PPE protective clothing.</p> <p>Do not touch any hot surfaces or parts bare handed.</p> <p>Always allow hot surfaces and parts to cool down first before touching or moving.</p> <p>If you are required to move hot parts, ensure you use proper tools and insulated welding gloves (PPE) to prevent burns to your hands and arms.</p>
	<p>Noise—Excessive noise may be harmful to hearing</p> <ul style="list-style-type: none"> ·Protect your ears by ear shields or other hearing protectors. ·Give warning to nearby personnel that noise may be potentially hazardous to hearing.

	<p>Risks due to magnetic fields</p> <p>The magnetic fields created by high currents may affect the operation of pacemakers or electronically controlled medical equipment.</p> <p>Wearers of vital electronic equipment should consult their physician before beginning any arc welding, cutting, gouging or spot welding operations.</p> <p>Do not go near welding equipment with any sensitive electronic equipment as the magnetic fields may cause damage.</p> <p>Keep the torch cable and work return cable as close to each other as possible throughout their length, this can help minimize your exposure to harmful magnetic fields.</p> <p>Do not wrap the cables around the body.</p>
	<p>Protection from moving parts</p> <p>When the machine is in operation keep away from moving parts such as motors and fans.</p> <p>Moving parts, such as the fan, may cut fingers and hands and snag garments.</p> <p>Protections and coverings may be removed for maintenance and controls only by qualified personnel after first disconnecting the power supply cable.</p> <p>Replace the coverings and protections and close all doors when the intervention is finished and before starting the equipment.</p> <p>Take care to avoid getting fingers trapped when loading and feeding wire during set up and operation.</p> <p>When feeding wire be careful to avoid pointing it at other people or towards your body.</p> <p>Always ensure machine covers and protective devices are in operation.</p>
	<p>Troubleshooting</p> <p>Before arc-welding machines are dispatched from the factory, they have already been checked thoroughly. The machine should not be tampered with or altered.</p> <p>Maintenance must be carried out carefully. If any wire becomes loose or is misplaced, it maybe potentially dangerous to user!</p> <p>Only professional maintenance personnel should repair the machine!</p> <p>Ensure the power is disconnected before working on the machine. Always wait 5 minutes after power switch off before removing the panels.</p> <p>If you still do not fully understand or cannot solve the problem after reading the instructions in this manual, you should contact the supplier or JASIC's service center immediately for professional help.</p>

1.2. Other precautions



Warning! Location

The machine should be located in a suitable position and environment. Care should be taken to avoid moisture, dust, steam, oil or corrosive gases. Place on a secure level surface and ensure that there is adequate clearance around the machine to ensure natural airflow.



Warning! The handle or strap on the welder is only suitable for manual lifting of the welder. If mechanical equipment such as crane is used to lift the welder, please ensure the welder is secured with suitable lifting equipment.



Warning!

Input connection

Before connecting the machine, you should ensure that the correct supply is available. Details of the machine requirements can be found on the data plate of the machine or in the technical parameters shown in the manual. The equipment should be connected by a suitably qualified competent person. Always ensure the equipment has a proper grounding.

Never connect the machine to the mains supply with the panels removed.

- 1) When the operator's movement is limited by the surroundings (for example, the operator can only bend his knees, barefoot, or lie down during operation), the operator shall practice proper insulation and avoid direct contact with conductive parts on the equipment.
- 2) Do not use the welder in closed containers in narrow spaces where conductive components cannot be removed.
- 3) Do not use the welder in humid environments where the operator is prone to the risk of electric shock.
- 4) Do not weld in sunlight or rain, and no water or rainwater shall seep into the welder.
- 5) Do not perform gas shielded welding in an environment with strong air flow.
- 6) Avoid welding in dusty area or environment with corrosive chemical gas.
- 7) The ambient temperature must be between -10° C and 40°C during operation and between -25°C and 50°C during storage.
- 8) Welding shall be carried out in a relatively dry environment, and the air humidity shall not exceed 90%.
- 9) The inclination of the welder shall not exceed 10°.
- 10) Ensure that the input power supply voltage does not exceed 15% of the rated voltage of the machine.
- 11) Beware of falling when welding at heights.

2. Description of symbols



Read this operation manual carefully before use



Operation warning



Single-phase static frequency converter-transformer rectifier



1 ~ 50/60Hz Single-phase AC power supply and rated frequency



Can be used in environments with high risk of electric shock

IP Degree of protection, such as IP23S.

U₁ Rated AC input voltage (tolerance $\pm 15\%$)

I_{1max} Rated maximum input current

I_{1eff} Maximum effective input current

X Duty cycle - the ratio of given duration time/full-cycle time

Note 1: This ratio is between 0-1, and can be indicated by percentage.

Note 2: In this standard, the full-cycle time is 10 min.

For example, if the duty cycle is 60%, the load application time is 6 min and the subsequent no-load time is 4 min.

U₀ No-load voltage, open circuit voltage of secondary winding

U₂ Load voltage

H Insulation class



Do not dispose electric waste with other ordinary waste.

Please take care of our environment.

T_{pre} Pre-flow

I_s Initial current

T_{up} Up-slope time

I_p Peak current

I_b Base current

T_{down} Down-slope time

I_f Finish current

T_{post} Post-flow time

T_{...} Spot welding time



Pulse frequency



Duty cycle



DC TIG mode



DC pulse TIG mode



MMA mode



HF arc starting mode



Lift arc starting mode



MMA current



Hot start current of MMA



Arc force of MMA



Welding mode switching



Other function switching



Remote control



Smart gas



VRD function indicator



Overcurrent protection indicator



Overheat protection indicator



Current unit "A"



Time unit "S"



Pulse frequency unit "Hz"



Duty cycle unit "%"



Wireless indicator



Pairing of wireless simple remote controller



Electric shock risk warning

3. Product overview

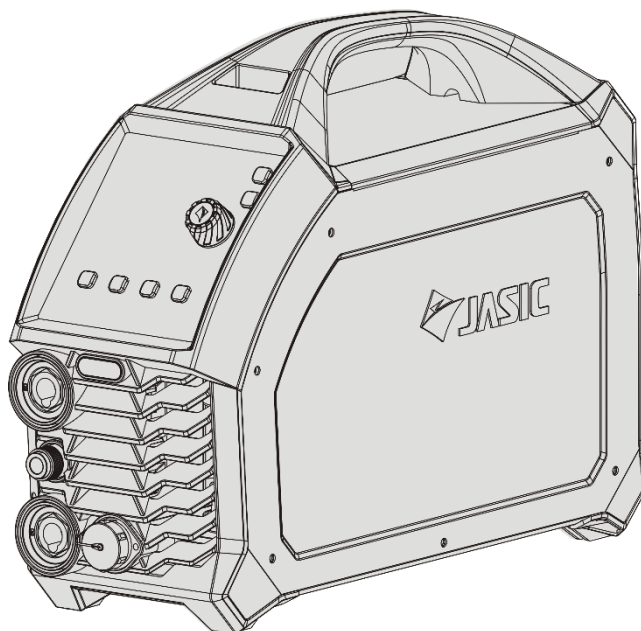

This is a digital control inverter DC welder with complete functionality, excellent performance and advanced technology, supporting **DC TIG, DC pulse TIG, TIG spot welding, and SMAW**. It can be widely used to weld common metals except aluminum and aluminum alloys. The unique electrical structure and air passage design inside the machine increases the dissipation of heat generated by the power device, thus improving its duty cycle. The machine also adopts a separated air passage design to effectively prevent water and dust from entering, thus greatly improving its reliability.

The interface is simple and easy to use. The appearance is streamlined from front to back, with a large arc between the front and back panels, so the two panels are naturally connected and integrated. The front and rear plastic panels have a soft texture and nice feel.

The machine enjoys features such as excellent welding performance, rich functionality, high efficiency, small volume, light weight, and low cost, meeting all welding requirements.

Note: The functions described above are only an overview of the series models. The specific functions are subject to the actual machine.

The main functions are:

- ◆ Welding mode: TIG200P PFC/TIG200P supports DC TIG, DC pulse TIG and MMA; TIG200PFC/TIG200 supports DC TIG and MMA.
- ◆ All welding parameters can be adjusted on the display for more accurate adjustment of the current and time parameters.
- ◆ Anti-stick function: Both MMA and TIG have an anti-stick function to prevent the welding electrode or tungsten electrode from sticking to the workpiece for a long time, causing short circuit and burning.
- ◆ The Smart gas function automatically matches the appropriate post-flow time according to the user's welding specifications, effectively saving argon.
- ◆ Smart fan control: Saves energy, reduces noise, reduces dust entry, and prolongs the

service life of the fan.

- ◆ TIG arc starting mode: Supports HF and lift arc starting with a high success rate.
- ◆ Multiple TIG operation modes: 2T, 4T, repeat, and spot welding.
- ◆ Parameters are automatically saved before shutdown, and the settings are restored after starting again.
- ◆ Compatible with various remote control methods: The plus version supports analog/digital remote control torch, wired/wireless foot pedal controller, and wireless handheld remote controller in TIG mode, and supports wired/wireless handheld remote controller in MMA mode; and the standard version supports analog remote control torch, wired foot pedal controller and wired handheld remote controller. Of course, wireless remote control requires a separate special receiving module and remote controller.
- ◆ Multiple user modes are supported. Users can restore factory settings, view barcodes on the machine, enable the standby function, set the response time, and enable input overvoltage and undervoltage protection.

4. Technical parameters

Item		Unit	Parameters			
Model		/	TIG200P PFC	TIG200 PFC	TIG200P	TIG200
Input voltage		VAC	AC95~265V	AC95~265V	AC230V±15%	AC230V±15%
Input frequency		Hz	50/60	50/60	50/60	50/60
Rated input current (AC230V)		A	19.5@TIG 25.6@MMA	19.5@TIG 25.6@MMA	27@TIG 29@MMA	27@TIG 29@MMA
Rated input current (AC115V)		A	29.7@TIG 31.6@MMA	29.7@TIG 31.6@MMA	/	/
Rated input power (AC230V)		kVA	4.5@TIG 5.9@MMA	4.5@TIG 5.9@MMA	6.2@TIG 6.7@MMA	6.2@TIG 6.7@MMA
Rated input power (AC115V)		kVA	3.4@TIG 3.7@MMA	3.4@TIG 3.7@MMA	/	/
No-load voltage		V	68	68	62	62
VRD voltage		V	10.5	10.5	10.5	10.5
TIG	Welding current (AC230V)	A	5~200	5~200	5~200	5~200
	Welding current (AC115V)	A	5~160	5~160	/	/
	Welding voltage (AC230V)	V	10.2 ~ 18	10.2 ~ 18	10.2 ~ 18	10.2 ~ 18
	Welding voltage (AC115V)	V	10.2 ~ 16.4	10.2 ~ 16.4	/	/
	Pre-flow time	s	0~3	0~3	0~3	0~3

	Initial current (AC230V)	A	5~200	5~200	5~200	5~200
	Initial current (AC115V)	A	5~160	5~160	/	/
	Up-slope time	s	0~10	0~10	0~10	0~10
	Down-slope time	s	0~10	0~10	0~10	0~10
	Finish current (AC230V)	A	5~200	5~200	5~200	5~200
	Finish current (AC115V)	A	5~160	5~160	/	/
	Post-flow time	s	0~15	0~15	0~15	0~15
	Base current (AC230V)	A	5~200	/	5~200	/
	Base current (AC115V)	A	5~160	/	/	/
	Pulse frequency	Hz	0.5~200	/	0.5~200	/
	Pulse duty factor	%	10~90	/	10~90	/
	Spot welding time	s	0.1~10	0.1~10	0.1~10	0.1~10
	Operation method		2T, 4T, repeat, spot welding	2T, 4T, repeat, spot welding	2T, 4T, repeat, spot welding	2T, 4T, repeat, spot welding
	Arc start mode		HF arc starting Lift arc starting	HF arc starting Lift arc starting	HF arc starting Lift arc starting	HF arc starting Lift arc starting
	Duty cycle		25%	25%	25%	25%
MMA	Welding current (AC230V)	A	10~180	10~180	10~160	10~160
	Welding current (AC115V)	A	10~120	10~120	/	/
	Welding voltage (AC230V)	V	20.4~27.2	20.4 ~ 27.2	20.4 ~ 26.4	20.4 ~ 26.4
	Welding voltage (AC115V)	V	20.4 ~ 24.8	20.4 ~ 24.8	/	/
	Hot start current	A	0~60	0~60	0~60	0~60
	Arc-force current	A	0~60	0~60	0~60	0~60
	Duty cycle		25%	25%	20%	20%

Power factor			0.99	0.99	0.68	0.68
Insulation class			H	H	H	H
Protection class			IP23S	IP23S	IP23S	IP23S
Dimensions L*W*H		mm	453*150*313	453*150*313	413*150*311	413*150*311
Net weight	Plus	Kg	8.97	8.97	7.92	7.92
	Standard		8.37	8.37	7.51	7.51
Overall total weight	Plus	Kg	13.63	13.63	12.55	12.55
	Standard		12.97	12.97	12.02	12.02
Power supply efficiency (at maximum input current)		%	84	84	86	86
Idle state power		W	44	44	25	25
Characteristics			CC	CC	CC	CC
Pollution level			Grade 3	Grade 3	Grade 3	Grade 3

5. Installation



Warning! All connections shall be made with the power supply is turned off.
Warning! Electric shock may cause death; after power failure, there is still a high voltage on the equipment, do not touch the live parts on the equipment.
Warning! Incorrect input voltage may damage the equipment.
Warning! This product meets the requirements of Class A equipment in EMC requirements and is not to be connected to a residential low-voltage power supply grid.

5.1. External interface description

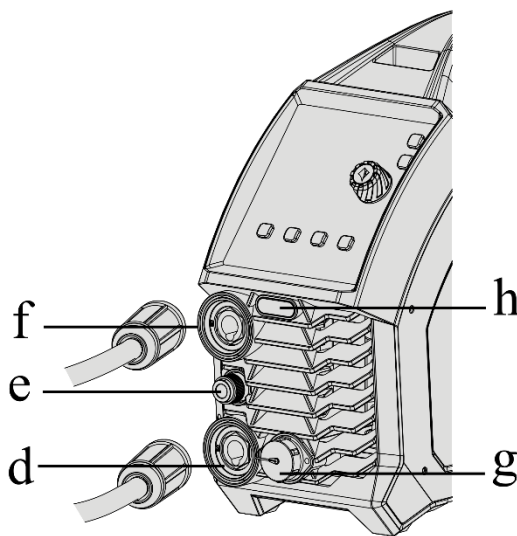

Figure 5-1 Front panel view

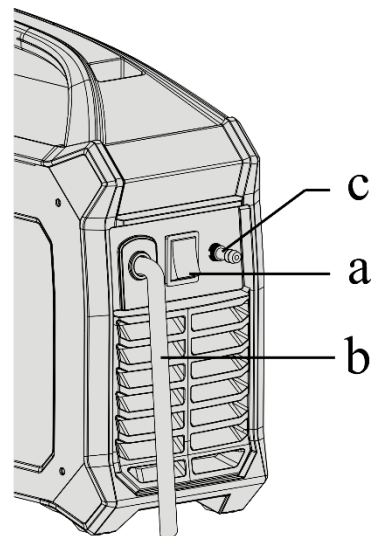

Figure 5-2 Rear panel view

- a. Power switch
- b. Input power cord
- c. Inlet nozzle
- d. Negative polarity
- e. TIG welding torch gas connector
- f. Positive polarity
- g. 9-pin aviation socket (plus)/7-pin aviation socket (standard)
- h. Wireless receiving module (optional)

5.2. Power installation



Warning! The electrical connection of equipment shall be carried out by suitably qualified personnel.

Warning! All connections shall be made after the power supply is off.

Warning! Incorrect voltage may damage the equipment.

- 1) Ensure the input voltage value is within the specified input voltage range.
- 2) Ensure that the power switch of the welder itself is turned off.
- 3) Connect the input power cord to the input terminal or plug the power cord into the corresponding socket (if any) and ensure a good contact.
- 4) Ground the power supply well. (As shown in the diagram, the European plug has a grounding terminal, so no additional grounding is required.)

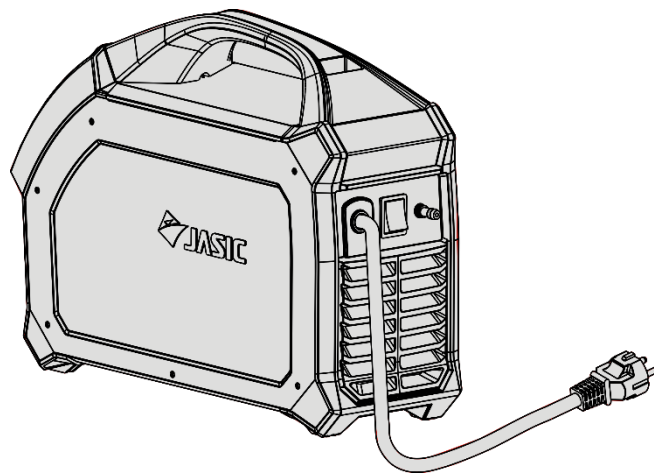

Figure 5-3 Power socket

NOTE!

If the input cable needs to be extended, please use a cable with larger cross-sectional area to reduce the voltage drop, 3x2.5mm² or more is recommended.

5.3. MMA electrode holder and earth cable connection

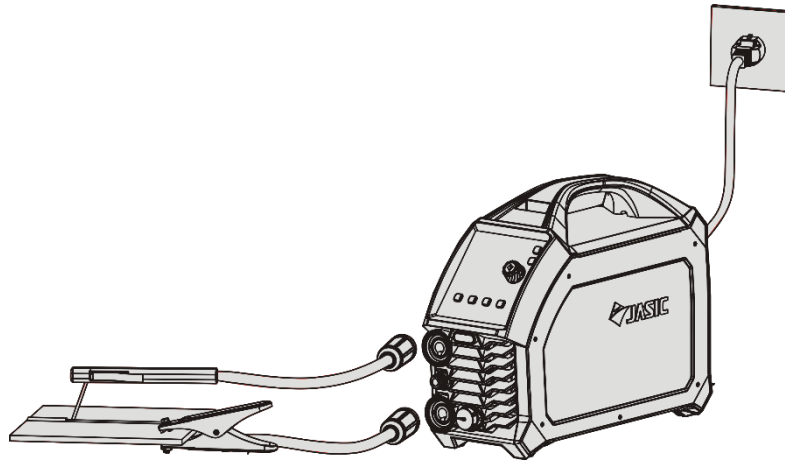

Figure 5-4 Electrode holder and earth cable

Pay attention to the polarity of wiring before MMA welding. Generally, there are two connection method of DC welder: DCEN and DCEP.

DCEN: The electrode holder is connected to the negative polarity, and the workpiece is connected to the positive polarity;

DCEP: The electrode holder is connected to the positive polarity, and the workpiece is connected to the negative polarity.

The operator can also choose DCEN based on the base metal and welding electrode.

Generally speaking, DCEP is recommended for basic electrodes (i.e., electrode connected to the positive polarity), while no special provisions are made for acid electrodes.

- 1) Ensure that the power switch of the welder itself is turned off.
- 2) Insert the cable plug with welding electrode holder into the corresponding socket on the front panel of the welder and tighten it clockwise.
- 3) Insert the cable plug with earth clamp into the corresponding socket on the front panel of the welder and tighten it clockwise.

NOTE! If you want to use long secondary cables (TIG torch cable and earth cable), you must ensure that the cross-sectional area of the cable is increased appropriately in order to reduce the voltage drop due to the cable length.

5.4. TIG welding torch and earth cable connection

- 1) Ensure that the power switch is turned off.
- 2) Insert the cable plug with earth clamp into the positive socket on the front panel of the welder and tighten it clockwise.
- 3) Insert the cable plug of the welding torch into the corresponding negative socket on the front panel of the welder and tighten it clockwise.

Note! The positive and negative polarities should not be reversed as this will prevent normal welding operation.

- 4) Insert the gas connector of the welding torch into the gas vent on the front panel.
- 5) Connect the gas hose of the argon cylinder to the inlet nozzle on the rear panel of the machine.

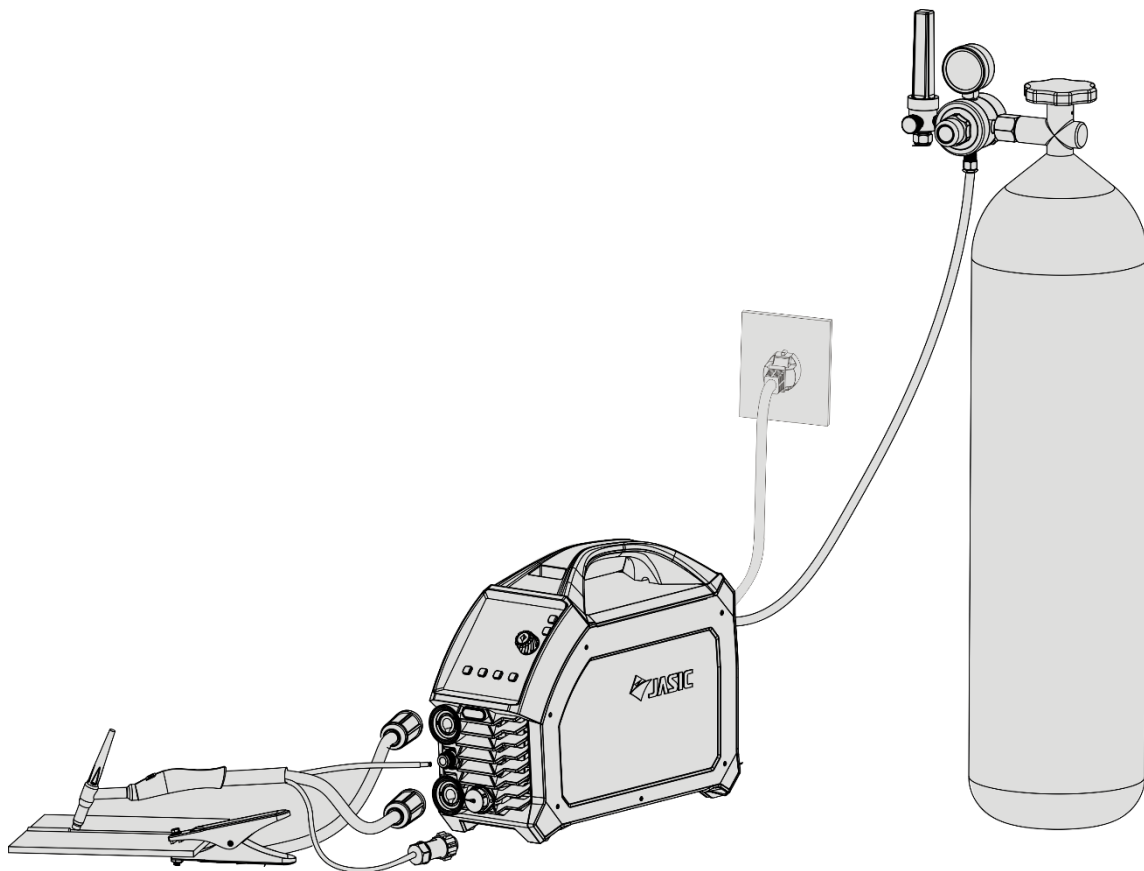

Figure 5-5 Connection of welding torch, earth cable and gas cylinder

NOTE! If you want to use long secondary cables (TIG torch cable and earth cable), you must ensure that the cross-sectional area of the cable is increased appropriately in order to reduce the voltage drop due to the cable length.

5.5. Wired handheld remote controller connection (optional)

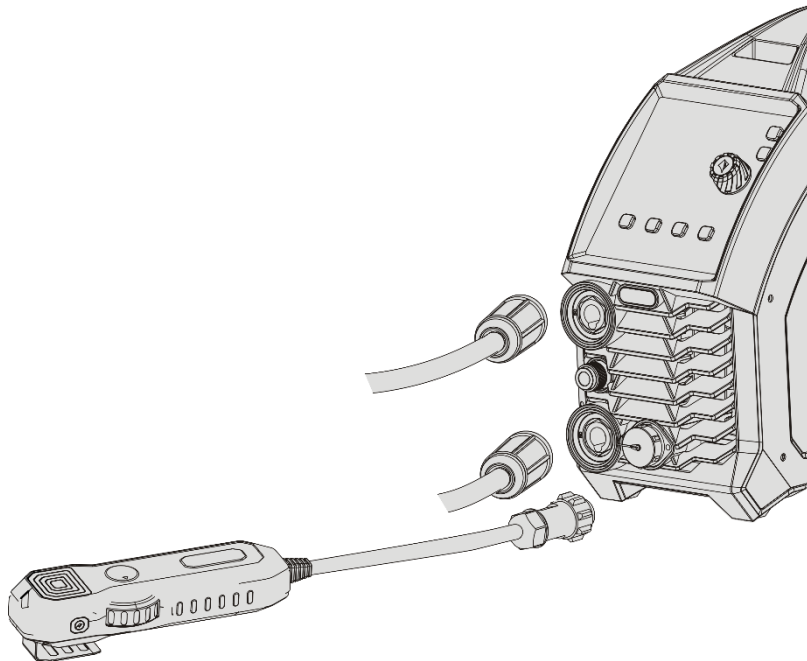

Figure 5-6 Connection of wired handheld remote controller

Insert the aviation plug of the handheld remote controller directly into the corresponding aviation socket of the machine.

NOTE: Please check that the machine supports wired handheld remote controller before installation.

5.6. Installation of wireless receiver module (optional)

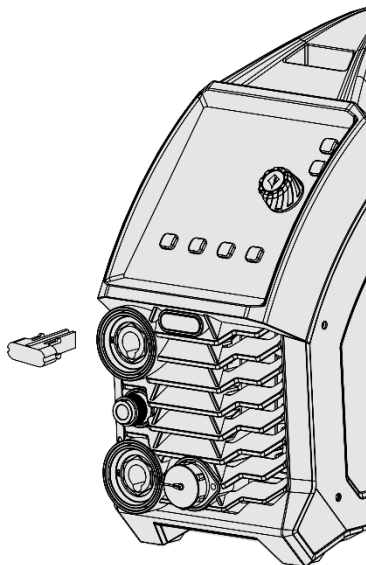

Figure 5-7 Pull out the plug

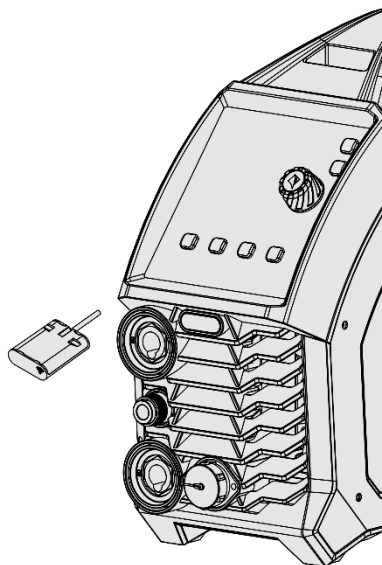

Figure 5-8 Install the wireless receiving module

Pull out the plug as shown in Figure 5-7, and replace the wireless receiving module as shown in Figure 5-8:

1) Remove the screws on the left cover of the machine.

- 2) Remove the buckle on the front panel inside the machine and pull out the wireless plug cover.
 - 3) Insert the wireless receiving module into the front panel, then connect the connection line of the receiver module to the CN10 socket on the mainboard.
- Note! Check with the seller whether the hardware and software versions of the machine support wireless remote controller before purchasing.**

6. Control panel

6.1. TIG200/TIG200PFC HD digital panel



Figure 6-1 HD digital panel

1. TIG parameter display
2. Parameters and error code display
3. Protection indicator
4. Welding mode selector
5. Arc start mode selector
6. Enable remote control
7. Smart gas
8. Parameter adjustment knob
9. VRD function indicator

- 10. MMA parameter selector
- 11. Operation mode selector

6.1.1 Display of TIG parameters

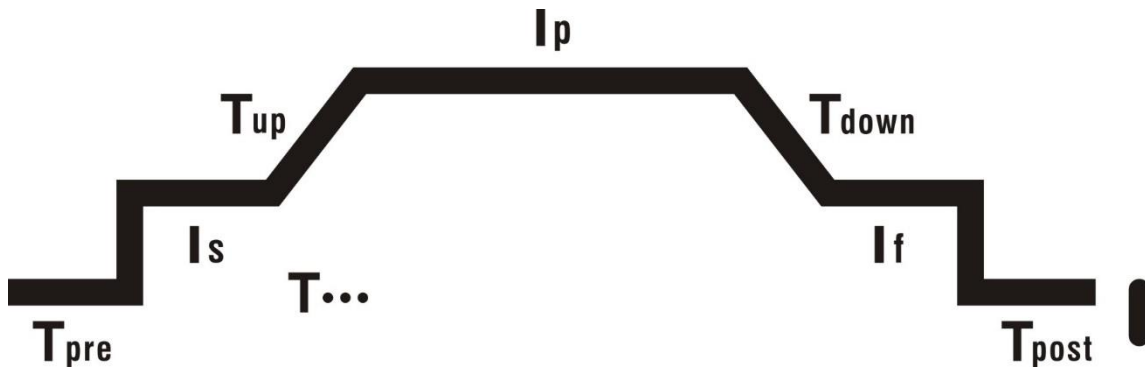

Figure 6-2 TIG parameter display

- 1) **T_{pre}**Pre-flow time indicator. When the indicator is on, it indicates the pre-flow protection time.
- 2) **I_s**Initial current indicator. When the indicator is on, it indicates the initial current.
- 3) **T_{up}**Up-slope time indicator. When the indicator is on, it indicates the time until the initial current reaches the peak current.
- 4) **I_p**Peak current indicator. When the indicator is on, it indicates the welding current.
- 5) **T_{down}**Down-slope time indicator. When the indicator is on, it indicates the time until the peak current drops to the finish current.
- 6) **I_f**Finish current indicator. When the indicator is on, it indicates the finish current.
- 7) **T_{post}**Post-flow time indicator. When the indicator is on, it indicates the post-flow time.
- 8) **T...**Spot welding time indicator. When the indicator is on, it indicates the spot welding time.

When the machine is started, in idle state (the state when the welding torch is not being used, the operation panel has no operation for over 5s, and the machine is not welding), or when switching mode, the TIG parameter indicator shows the peak current, which can be adjusted by rotating the encoder. The indicator flashes during the adjustment, but does not flash before/after adjustment.



6.1.2 Display of parameters and error codes



Figure 6-3 Value display



- 1) The meter shows the parameter value
- 2) "A" is the current unit indicator. The "A" indicator will be on when it is switched to the current parameter
- 3) "S" is the time unit indicator. The "S" indicator will be on when it is switched to the time parameter
- 4) "%" is the duty cycle indicator. The "%" indicator will be on when it is switched to duty cycles
- 5) "Hz" is the frequency unit indicator. The indicator will be on when it is switched to frequency
- 6) An error code is displayed when the product is abnormal

6.1.3 Protective indicators

- 1) When the overheat indicator  is on, it indicates that the welder is in overheat protection and has stopped output
- 2) When the overcurrent indicator  is on, it indicates that the welder is in overcurrent protection and has stopped output



6.1.4 Selection of welding mode



- 1) Before welding, press the welding mode key  to switch between MMA and DC TIG welding, and select the corresponding mode based on the process requirements.
- 2) If the indicator  is on, it indicates that DC TIG mode has been selected.
- 3) If the indicator  is on, it indicates that the MMA mode has been selected.



6.1.5 Selection of arc starting mode



- 1) Before welding, press the welding mode key  to switch between lift arc starting and HF arc starting, and select the corresponding mode based on the process requirement.
- 2) If the indicator  is on, it indicates that the HF arc starting mode has been selected.
- 3) If the indicator  is on, it indicates that the lift arc starting mode has been selected.



6.1.6 Enabling remote control



- 1) Before welding, press the remote control function key  to enable the remote control function.
- 2) If the indicator  is on, it indicates that the remote control function has been enabled. If the remote controller is connected, it controls the welding current. If no remote controller is connected, the welding current is controlled by the panel adjuster.
- 3) If the indicator  is not on, it indicates that the remote control function has been disabled, and the welding current is being controlled by the panel adjuster.

6.1.7 Smart gas





Press the  key to enable Smart gas. If the indicator  is on, it indicates that the machine is in Smart gas mode. This function automatically matches the appropriate post-flow time according to the user's welding specifications, effectively saving argon.

6.1.8 Parameter adjustment knob

- 1) Rotate the adjustment knob to adjust the parameter.
- 2) Rotate the knob clockwise to increase the value, and counterclockwise to decrease the value.
- 3) When the knob is rotated, the adjustment is displayed in the parameter display area. The





progress bar on the left side of the knob is adjusted proportionally with the value.

6.1.9 VRD Function Indicator

- 1) When the VRD function is disabled, the VRD indicator is not on.
- 2) When the VRD function is enabled and no welding is being performed and the VRD indicator  is green, it indicates that the VRD function is normal.
- 3) When the VRD function is enabled and no welding is being performed and the VRD indicator  is red, it indicates that the VRD function is abnormal.
- 4) When the VRD function is enabled, the VRD indicator is not on during welding.



6.1.10 Selection of MMA parameters

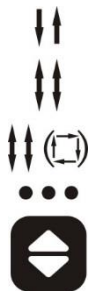

- 1) Press the key  to select MMA parameters, and rotate the knob to adjust the parameter value.
- 2) If the indicator  is on, it indicates the MMA welding current.
- 3) If the indicator  is on, it indicates the MMA hot start current.
- 4) If the indicator  is on, it indicates the MMA arc-force current.

6.1.11 Selection of operation mode



- 1) Press the key  to select the TIG operation mode.
- 2) If the indicator  is on, it indicates that the machine is in 2T mode.
(In 2T mode, after pressing the torch trigger, the machine will start a high-frequency arc after the pre-flow time, then reach the peak current from the initial current after the preset up-slope

time; after releasing the trigger, the machine will drop to finish current from peak current after the preset down-slope time, then the arc will extinguish, and the operation will end after the post-flow time.)

3) If the indicator  is on, it indicates that the machine is in 4T mode.
 (In 4T mode, after pressing the torch trigger, the machine will start a high-frequency arc after the pre-flow time, then output the initial current; after releasing the trigger, it will reach the peak current from the initial current after the preset up-slope time; after pressing the trigger again, it drops to finish current from peak current after the preset down-slope time; and after releasing the trigger again, the arc extinguishes and the operation ends after the post-flow time.)

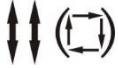



4) If the indicator  is on, it indicates the machine is in repeat operation mode.
 (In repeat mode, after pressing the torch trigger, the machine will start a high-frequency arc after the pre-flow time, and reach the peak current from the initial current after the preset up-slope time; after releasing the trigger, the machine will drop to finish current from peak current after the preset down-slope time; after pressing the trigger again, it rises to peak current after the preset up-slope time; and after releasing the torch trigger again, it drops to the finish current after the preset down-slope time, and so on. If the torch trigger is quickly double-tapped within 300ms, the arc extinguishes and the process ends after the post-flow time.)

5) If the indicator ●●● is on, it indicates the machine is in spot welding mode.
 (In spot welding mode, after pressing the torch trigger, the machine will start a high-frequency arc after the pre-flow time, then output welding current. After repeatedly pressing the torch trigger, the arc automatically extinguishes after the pre-set spot welding time. Then, to restart the arc, press the trigger again. If the trigger is released before the set spot welding time, the arc will extinguish immediately.)

6.1.12 Use of remote controller

6.1.12.1 Wireless remote controller

1) **Wireless pairing:** Before welding, press and hold the panel remote control function



button  and the pairing button of the wireless simple remote controller at the same time for 2 seconds to pair the wireless remote controller. During pairing, the blue wireless receiver module indicator  flashes; after successful pairing, the remote control mode indicator  will be on. At the same time, the blue indicator  of the wireless receiver module will remain on and the welder display window will display "OK".

2) **Disconnecting the wireless connection:** After the remote controller is successfully paired, press and hold the pairing button of the wireless remote controller, or the remote control function button on the panel, and the wireless connection will be disconnected. After

disconnecting, the display window of the welder will display "FAL", and the green indicator

 of the wireless receiver module will remain on.

6.1.12.2 Wired remote controller

Press the remote control key , and the remote control indicator  will turn on; insert the aviation plug of the wired remote controller into the aviation socket to adjust the welding current through the remote controller.

6.1.12.3 Optional remote control models

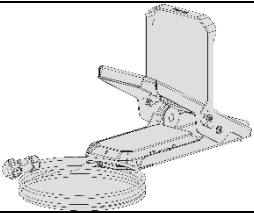
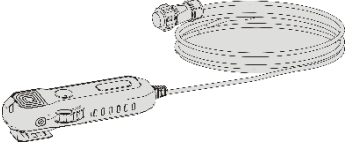
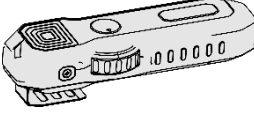
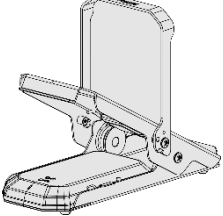
Type	Name	Model	Host receiver module	Welding mode	Picture
Wired	Analog torch trigger	10K potentiometer Analog welding torch	None	TIG	
	Digital torch trigger	Digital welding torch	None	TIG	
	Wired foot remote controller	FRC-01(P1S 3)	None	TIG	
	Wired handheld remote controller	HRC-01(P1S 1)	None	MMA	
Wireless	Wireless handheld remote controller	HRC-02(P1S 2)		TIG/MMA	
	Wireless foot remote controller	FRC-02(P1S 4)		TIG	

6.2. TIG200P/TIG200P PFC HD digital panel

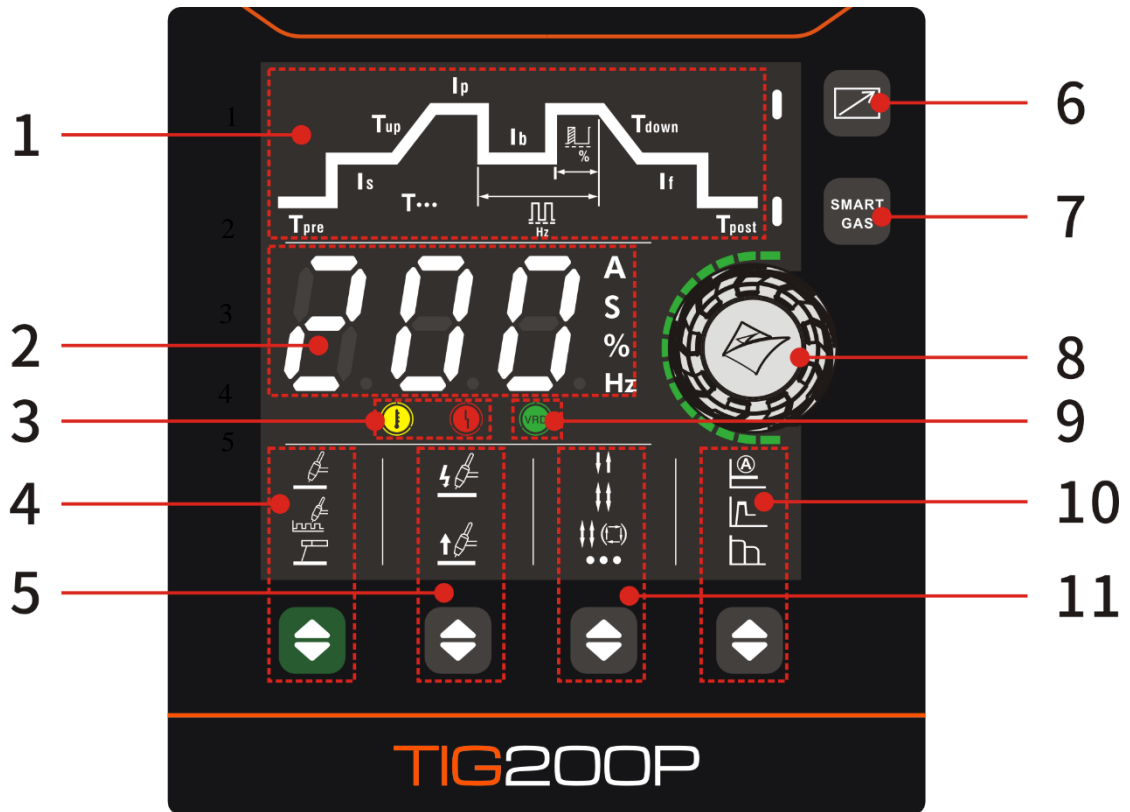

Figure 6-4 HD digital panel

1. TIG parameter display
2. Parameter and error code display
3. Protection indicator
4. Welding mode selector
5. Arc start mode selector
6. Enable remote control (optional)
7. Smart gas
8. Parameter adjustment knob
9. VRD function indicator
10. MMA parameter selector
11. Operation mode selector

6.2.1 Display of TIG parameters

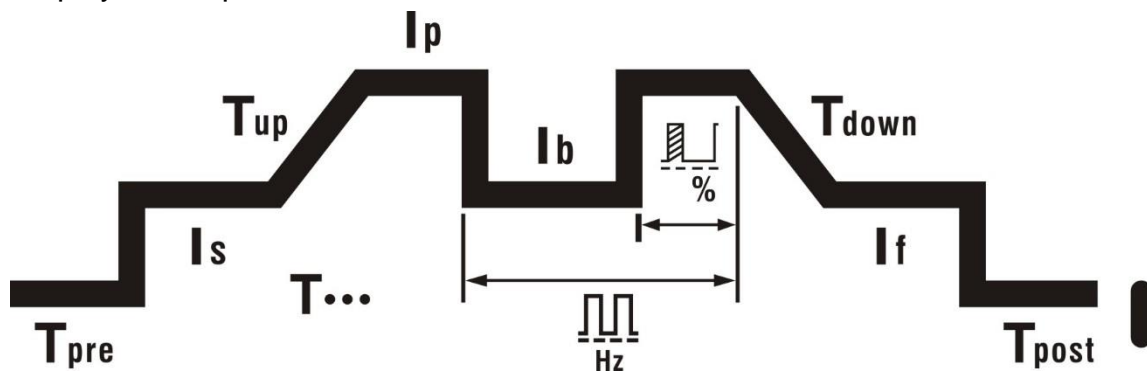



Figure 6-5 TIG200P HD digital panel

- 1) **T_{pre}** Pre-flow time indicator. When the indicator is on, it indicates the pre-flow protection time
- 2) **I_s** Initial current indicator. When the indicator is on, it indicates the initial current
- 3) **T_{up}** Up-slope time indicator. When the indicator is on, it indicates the time until the initial current reaches the peak current
- 4) **I_p** Peak current indicator. When the indicator is on, it indicates the welding current
- 5) **I_b** Base current indicator. When the indicator is on, it indicates the pulse base current
- 6) **T_{down}** Down-slope time indicator. When the indicator is on, it indicates the time until the peak current drops to the finish current
- 7) **I_f** Finish current indicator. When the indicator is on, it indicates the finish current
- 8) **T_{post}** Post-flow time indicator. When the indicator is on, it indicates the post-flow time
- 9) **T_{...}** Spot welding time indicator. When the indicator is on, it indicates the spot welding time
- 10)  Hz Pulse frequency indicator. When the indicator is on, it indicates the pulse frequency
- 11)  % Duty-cycle indicator. When the indicator is on, it indicates the ratio of peak current time to pulse period

6.2.2~6.2.3

(Same as 6.1.2-6.1.3)

6.2.4 Selection of welding mode



1) Before welding, press the welding mode key  to switch among MMA, DC TIG and DC pulse TIG welding, and select the corresponding mode based on the process requirements.

2) If the indicator  is on, it indicates the DC TIG mode is selected.

3) If the indicator  is on, it indicates the DC pulse TIG mode is selected.

4) If the indicator  is on, it indicates the MMA mode is selected.

6.2.5~6.2.12

(Same as 6.1.5-6.1.12)

6.3. Other functions

6.3.1 Standby

1) Press and hold the "Current Setting Encoder" key for 2s to start the countdown. After the 3s countdown is over, the panel displays "F01"; press the key again to enter standby response time settings.

2) Rotate the "Current Setting Encoder" to adjust the standby response time, increasing clockwise and decreasing counterclockwise. (The standby response time includes four levels: 0, 5, 10, 15, where 0 means disabled, and other numbers correspond to the response time, in minutes. The default value is 10.)

3) After adjusting the standby response time, press the "Current Setting Encoder" key to save the current settings.

4) Press the welding mode key  to complete the operation and exit.

5) The standby function is only available in TIG mode. If the machine is not used within the set response time, it will enter standby state, and only the middle bar of the first digit on the display panel will flash at a frequency of 1Hz. The machine will wake up immediately when the torch trigger, operation panel, or remote controller is used.



Figure 6-6 Standby function indicator

6.3.2 Input overvoltage and undervoltage protection



Figure 6-7 Enter the back-end

- 1) Press and hold the "Current Setting Encoder" key for 2s to start countdown. After the 3s countdown is over, the panel displays "F01". Rotate the "Current Setting Encoder" key clockwise to adjust the parameter to "F02", and press the key again to enter the input overvoltage and undervoltage protection settings.
- 2) Rotate the "Current Setting Encoder" key to adjust the overvoltage and undervoltage protection state, increasing clockwise and decreasing counterclockwise (0: not enabled; 1: enabled).
- 3) After adjusting the standby response time, press the "Current Setting Encoder" key to save the current settings.
- 4) Press the welding mode key  to complete the operation and exit.

(The standard version only supports overvoltage protection function. This function is enabled by default.)

6.3.3 Restore factory settings

Press and hold the welding mode key  for 5s to restore factory settings. After holding for 1s, the display window will start to count down from 3. When the countdown ends, the factory settings are restored. If the button is released before the countdown ends, the restoration will not take place. The factory settings are as shown in Table 6-1.



Figure 6-8 Restore factory settings

Table 6-1 Factory settings

Welding mode	Pre-flow time (s)	Initial current (A)	Up-slope time (s)	Peak current (A)	Base current (A)	Down-slope time (s)	Finish current (A)	Post-flow time (s)	Spot welding time (s)	Pulse frequency (Hz)	Duty cycle (%)	Welding current (A)	Hot start current (A)	Arc-force current (A)
DC TIG	0.5	10	0.5	100	—	0.5	10	2	1	—	—	—	—	—
Pulse TIG	0.5	10	0.5	100	50	0.5	10	2	—	50	50	—	—	—
MMA	—	—	—	—	—	—	—	—	—	—	—	80	30	30

Note: TIG200 and TIG200 PFC do not have the pulse TIG factory settings.

6.3.4 Barcode display



Figure 6-9 View barcode

Press and hold the "Current Setting Encoder" and "Welding Mode" keys  simultaneously for 3s to view the machine barcode. Press any key or press the encoder to immediately exit the barcode display. If you do not perform any operation on the panel, the barcode automatically exits after 20s.

6.3.5 VRD function



Warning! The electrical connection of the machine must be completed by electricians with qualification certificates.

Warning! Electric shock may cause death; after power failure, the machine will still have high voltage, so do not touch the live parts.

The MMA VRD mode is enabled by default in the factory settings, and the user can disable it as required.

- 1) Open the left cover of the machine with the machine powered off.
- 2) Turn the DIP switch SW1 to "12" on the panel PN-212(TIG200P PFC/TIG200PFC) or PN-213(TIG200P/TIG200) to disable VRD.
- 3) Put the cover back and turn on the power; switch to MMA mode and the VRD indicator



will be on. At this time, the no-load voltage of the welder is 11.5V.

7. Welding function operation



Warning! Before turning on the power supply make sure that the electrode holder or welding torch is connected to the output, do not touch the workpiece and earth clamp. Otherwise, an unexpected arc may be started when the power is turned on in the case of MMA by default. This can cause damage to the workpiece and to personnel.



Warning! Be sure to wear appropriate protective equipment during welding operation. Arcs, spatter, smoke, and high temperatures produced in the welding process may cause injury to personnel.



Warning! After the power supply is turned off, the output voltage of the welder may continue for a period and then drop slowly. Please do not touch the conductive part of the output before the panel is extinguished.

7.1. MMA operation

7.1.1 Turn on the power switch

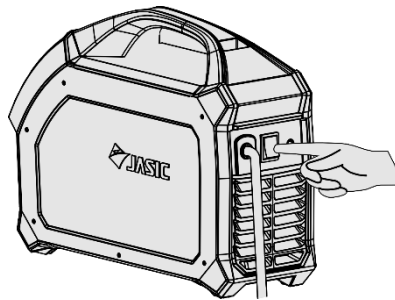

Figure 7-1 Power switch position

The power switch is located at the rear panel of the machine; set it in the "ON" position; then the panel indicator will light up, the fan will start to rotate, and the welder will start to work normally.

Note! Some models have the function of smart fan. When the power supply is turned on for a period of time without welding, the fan will automatically stop running. It will run automatically when it is welded.

7.1.2 Select manual welding mode



Figure 7-2 MMA panel display

The rotary encoder can adjust the welding current, hot start current and arc force current parameters.

Welding current: The current of the arc section during welding, which is set by the user based on the type and diameter of the welding electrode and the process requirements. Refer to Table 7-1:

Table 7-1 Selection of welding electrode diameter and welding current

No.	Workpiece thickness (mm)	Welding electrode diameter range (mm)	Welding electrode diameter (mm)	Welding current (A)
1			1.6	25~40
2	≤4	2.0~3.2	2.0	40~65
			2.5	50~80
			3.2	100~130
3	4~12	3.2~4.0	3.2	100~130
			4.0	160~210
4	> 12	≥4	5.0	200~270
			6.0	220~300

Arc-force: The arc force value should be determined according to welding electrode diameter, current setting, and process requirements. With large arc force current, the metal transfers quickly and the droplets don't stick, but excessive current increases spatter; low current leads to small spatter and good weld seam formation, but sometimes the arc is soft, or causes droplets to stick. In particular, thick electrodes with low current welding require increased arc force. Generally, the current is 0-40.

Hot start current: Stronger hot start current is conducive to arc start and reduces sticking between the welding electrode and workpiece during arc start. The magnitude of hot start current is generally determined based on the type, specification, and welding current of the

welding electrode. For electrodes with sound arc start performance and small diameter, generally select small hot start current; large welding current also has little requirement for hot start current.

NOTE! The operator should set the functions that meet the welding requirements. If the selections are incorrect this may lead to problems such as an unstable arc, spatter, or sticking of the welding electrode to the workpiece.

During DC welding the heat on the positive and negative polarities of the welding arc is different. When welding using DC power supply, there are DCEN and DCEP connections. The DCEN connection refers to the welding electrode connected to the negative polarity of the power supply and the workpiece connected to the positive polarity of the power supply. In this mode the workpiece receives more heat, resulting in high temperature, deep penetration, easy to weld through, suitable for welding thick parts. The DCEP connection refers to the welding electrode connected to the positive polarity of the power supply and the workpiece connected to the negative polarity of the power supply. In this mode the workpiece receives less heat, resulting in low temperature, shallow pool, and less penetration. This is suitable for welding thin parts.

NOTE! This product has anti-stick function by default. When VRD is enabled, if short circuit occurs for 2 seconds during the welding process, the machine will automatically enter anti-stick function and the welding current will automatically drop to 10A; when VRD is disabled, if short circuit occurs for 2 seconds during the welding process, the machine will automatically enter anti-stick function and the output current will be 0.

7.1.3 Turn off the power supply after welding

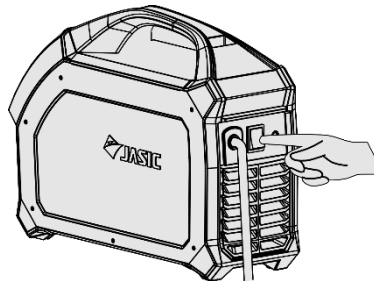

Figure 7-3 Power switch position

The power switch is located on the rear panel of the machine and set it to the "off" position. After a time delay, the panel indicator is off and the welder stops working.

7.2. DC TIG operation

7.2.1 Turn on the power switch
(Same as 7.1.1)

7.2.2 Select DC TIG welding mode

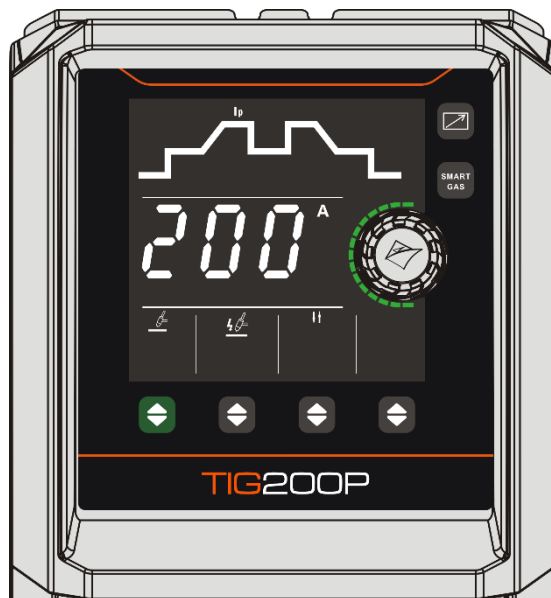

Figure 7-4 DC TIG mode

7.2.3 Select the arc starting mode

The arc starting mode includes lift arc starting and HF arc starting, which can be selected according to the actual conditions.

7.2.4 Select welding method

The welding methods are spot welding, 2T welding, 4T welding and repeat welding, and can be selected according to the actual conditions. Refer to Table 7-2 for details.

Table 7-2 Welding method description

Legend for commonly-used torch trigger operations			
↓	Press the torch trigger	↑	Release the torch trigger
Mode No.	Operation Schedule	Torch trigger operation and typical DC TIG current curve	
1	<p>Spot welding mode:</p> <ol style="list-style-type: none"> 1. Press the torch trigger to start the arc to the set value; 2. The arc extinguishes after the spot welding finishes running for the set time. 		
2	<p>2T mode:</p> <ol style="list-style-type: none"> 1. Press the torch trigger to increase the arc up to the designated peak current 2. Release the trigger to slowly extinguish the arc 3. If the trigger is pressed again before the arc is extinguished, it will slowly increase to the peak current 		
3	<p>4T mode:</p> <ol style="list-style-type: none"> 1. Press the torch trigger to start the arc to the initial value 2. Release the trigger to slowly increase to the peak current 3. Press the trigger to slowly drop to the finish current 4. Release the trigger to extinguish the arc 		
4	<p>Repeat mode:</p> <ol style="list-style-type: none"> 1. Press the torch trigger to start the arc to the initial value 2. Release the trigger to slowly increase to the peak current 3. Press the trigger to slowly drop to the finish current 4. Release the trigger to slowly step up to the peak current 5. Repeat steps 3 and 4 until the 		

	arc is extinguished by pressing the torch trigger twice within 300ms.	
--	-----------------------------------------------------------------------	--

7.2.5 Set welding parameters

The DC TIG welding parameters are as shown in Figure 7-5.

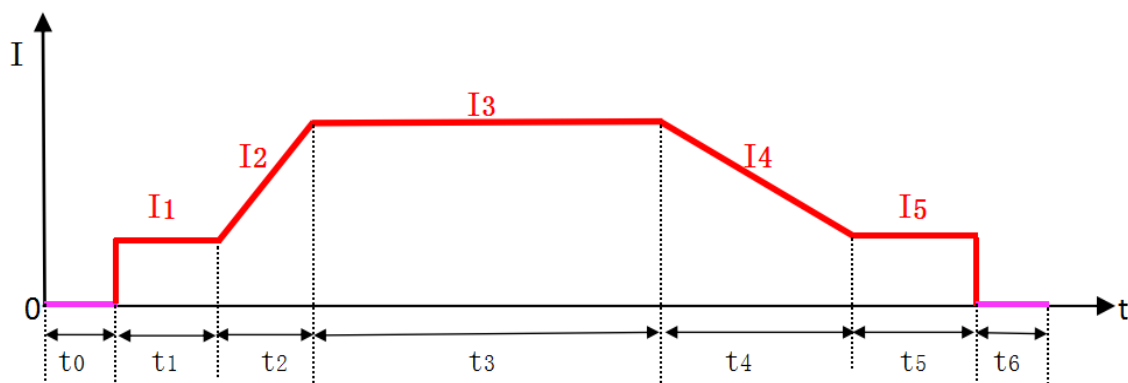

Figure 7-5 Current waveform of DC TIG

- | | |
|--------------------------------------------------------------------------------------------------------------------------------------------------------------------------------------------------------------|----------------------------------------------------------------------------------------------------------------------------------------------------------------------------------------------------------------------------------------------------------|
| <ul style="list-style-type: none"> I1-Initial current I2-Current during up-slope time I3-Peak current I4-Current during down-slope time I5-Finish current | <ul style="list-style-type: none"> t0-Pre-flow time t1-Initial current period t2-Up-slope time t3-Peak current period t4-Down-slope time t5-Finish current period t6-Post-flow time |
|--------------------------------------------------------------------------------------------------------------------------------------------------------------------------------------------------------------|----------------------------------------------------------------------------------------------------------------------------------------------------------------------------------------------------------------------------------------------------------|

- Initial current (I1): The initial current is the current after the torch trigger is pressed to start the arc, which should be determined according to the process requirements. A large initial current makes it easy to start the arc, but it should not be too large when welding thin plates, otherwise, it may burn through the workpiece. After the arc is started in 4T operation, the current remains at the initial current to achieve the purpose of preheating the workpiece or lighting.
- Up-slope time (t2): Refers to the time as the current slowly rises from the initial current to the peak current, which can be determined according to the usage and process requirements.
- Peak current (I3): Set by the user according to the actual process requirements.
- Down-slope time (t4): Down-slope time refers to the as when the current drops from the peak to the finish current, which can be determined according to the usage and process requirements.
- Finish current (I5): In 4T operation mode, the arc is not extinguished after the current down-slope and remains in a state of continuous arcing, which can avoid weld defects or large craters caused by immediately cutting off the output. The operating current in this state

is called the finish current, which should be determined according to the process requirements.

- Pre-flow time (t0): Refers to the time from pressing the torch trigger to sending argon gas to arc starting. Generally, it should be greater than 0.5s to ensure that the gas has been sent to the welding torch at normal flow when discharging arc initiation. It should be increased when the gas pipe is long.
- Post-flow time (t6): Refers to time from cutting off the welding current to turning off gas the valve in the welder. It should be determined according to the usage conditions and process requirements; too long will cause waste of argon gas, but too short will cause oxidation of the weld.

The parameters are set as follows:

Enter DC TIG mode, and press the encoder to select the welding parameter to be set. If the parameter indicator is on, it indicates that the parameter is selected.

Press the encoder once. If the indicator is on, it indicates that the parameter has been selected for configuration; rotate it clockwise to increase the value, and counterclockwise to decrease the value.

After setting the parameter, press the encoder again to save the current settings, and the parameter indicator will change to always on.

Set all the welding parameters according to the above steps.

Choose the appropriate welding current, tungsten electrode, and shielding gas flow based on the welding requirements. Refer to the Table 7-3 for details.

Table 7-3 Stainless steel plate-selection of parameters for manual TIG arc welding

Tungsten diameter (mm)	Thickness of stainless steel plate (mm)	Maximum current (A)	Maximum argon flow rate (l/min)
1~2	1~3	50	5
		50~80	6
2~4	3~6	80~120	7
		121~160	8
		161~200	9
		201~300	10

7.2.6 DC TIG welding

Open the gas valve on the gas cylinder, adjust the argon gas flow, and realize TIG welding by lift arc starting or HF arc starting.

During welding:

- 1) The TIG parameter indicator changes with the welding state
- 2) If the parameter indicator is in initial current, peak current, or finish current, directly press the encoder to adjust the value, and the parameter indicator will flash
- 3) If the parameter indicator is in pre-flow time, up-slope time or down-slope time, the value cannot be adjusted, and operations on the encoder will not be effective.

After welding, release the torch trigger to extinguish the arc.

Note! When starting the arc, if the short-circuit time exceeds 2 seconds, the welder turns off the output current. Lift the welding torch to restart the arc again.

Note! During welding, if there is short circuit between tungsten electrode and the workpiece, the welder will immediately reduce the output current; if the short circuit exceeds 1 second, the welder will turn off the output current. If this happens, lift the welding torch to restart the arc again.

7.2.7 Turn off the power supply after welding
(Same as 7.1.4)

7.3 DC pulse TIG operation

7.3.1 Turn on the power switch
(Same as 7.1.1)

7.3.2 Select DC pulse TIG welding mode



Figure 7-6 DC pulse TIG welding mode

7.3.4 Select welding method
(Same as 7.2.4)

7.3.5 Set welding parameters

The DC pulse TIG welding parameters are as shown in Figure 7-7.

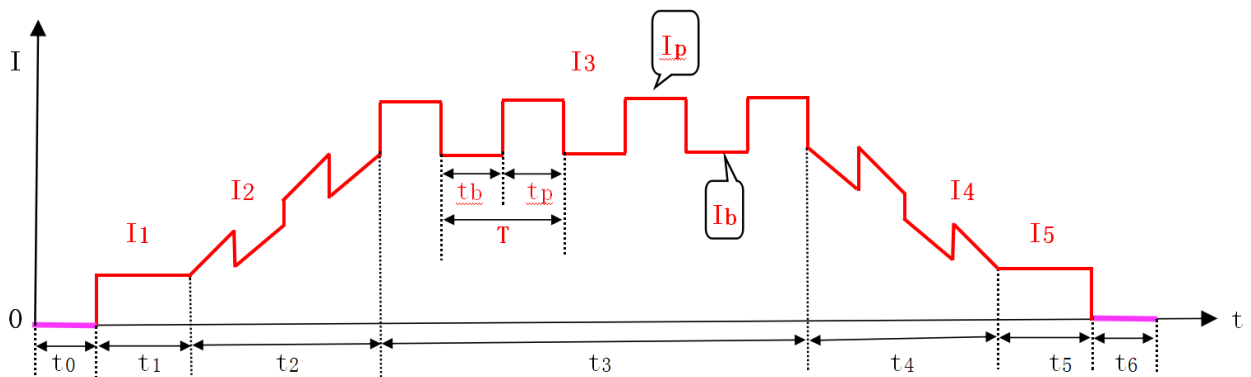

Figure 7-7 Current waveform of DC pulse TIG

- | | |
|-----------------------------------|-----------------------------|
| I1-Initial current | t0-Pre-flow time |
| I2-Current during up-slope time | t1-Initial current period |
| I3-Pre-set pulse current | t2-Up-slope time |
| I4-Current during down-slope time | t3-Peak/base current period |
| I5-Finish current | t4-Down-slope time |
| IP-Pulse peak current | t5-Finish current period |
| Ib-Pulse base current | t6-Post-flow time |
| | tb-Pulse base time |
| | tp-Pulse peak time |
| | T-Pulse period |

Pulse TIG includes all DC TIG parameters, except that the parameters are set differently. The parameters will not be explained again here. In addition, there are 4 adjustable parameters, which are explained separately in conjunction with the figure:

- Peak current (I_p): Maximum pulse current, adjusted according to the process requirements.
- Base current (I_b): Minimum pulse current, adjusted according to the process requirements.
- Pulse frequency ($1/T$): $T=tp+tb$, adjusted according to the process requirements.
- Duty cycle ($100\% \cdot tp/T$): the percentage of peak current duration in the pulse cycle, adjusted according to the process requirements.

The parameters are set as follows:

Enter DC TIG mode, and press the encoder to select the welding parameters to be set. If the parameter indicator is on, it indicates that the parameter is selected.

Press the encoder once. If the indicator is on, it indicates that the parameter has been selected; press the encoder clockwise to increase the value, and counterclockwise to decrease it.

After setting the parameter, press the encoder again to save the current settings, and the parameter indicator will change to always on.

Set all welding parameters according to the above steps.

Choose the appropriate welding current, tungsten electrode, and shielding gas flow based on the welding requirements. Refer to the Table 7-3 for details.

7.3.6 DC pulse TIG welding

Open the valve on the gas cylinder, adjust the argon flow, and realize TIG welding by lift arc starting or HF arc starting.

During welding:

- 1) The TIG parameter indicator changes with the welding state
- 2) If the parameter indicator is in initial current, peak current, base current or finish current, directly press the encoder to adjust the value, and the parameter indicator will flash
- 3) If the parameter indicator is in pre-flow time, up-slope time or down-slope time, the value cannot be adjusted, and operations on the encoder will not be effective

After welding, release the torch trigger to extinguish the arc.

7.3.7 Turn off the power supply after welding

(Same as 7.1.4)

8. Maintenance



Warning!

The following operation requires sufficient professional knowledge on electric aspects and comprehensive safety knowledge. Make sure the input cable of the machine is disconnected from the electricity supply and wait for 5 minutes before removing the machine covers.

Please note: The following should only be carried out by an authorised electrical technician.

8.1. Power supply maintenance

In order to guarantee that the arc welding machine works efficiently and in safety, it must be maintained regularly. Operators should understand the maintenance methods and means of arc welding machine operation. This guide should enable customers to carry out simple examination and safeguarding by oneself, try to reduce the fault rate and repair times of the arc-welding machine, so as to lengthen service life of arc welding machines.

<u>Period</u>	<u>Maintenance item</u>
Daily examination	Check the condition of the machine, mains cables, welding cables and connections. Check for any warnings LEDs and machine operation.
Monthly examination	Disconnect from the mains supply and wait for at least 5 minutes before removing the cover. Check internal connections and tighten if required. Clean the inside of the machine with a soft brush and vacuum cleaner. Take care not to remove any cables or cause damage to components. Ensure that ventilation grills are clear. Carefully replace the covers and test the unit. This work should be carried out by a suitably qualified competent person.
Yearly examination	Carry out an annual service to include a safety check in accordance with the manufacturers standard (EN 60974-1). This work should be carried out by a suitably qualified competent person.

8.2. Welding torch maintenance

In Lift TIG mode, the TIG welding torch is used to clamp the electrode, conduct electricity and transport argon gas.

Regular maintenance of welding torch is one of the most important measures to ensure its normal operation and improve its life. In order to ensure normal maintenance, the wearing

parts of the torch should have spares, including the electrode holder, nozzle, sealing mesh, insulating washer, etc. Common faults of the welding torch include overheating, gas leakage, water leakage, poor gas protection, power leakage, nozzle burn out, and cracking. The causes of these faults and troubleshooting methods are as shown in the following table:

Symptom	Reasons	Troubleshooting
The welding torch is overheated	The welding torch capacity is too small	Replace with a welding torch with one with large capacity
	The cooling water pipe is blocked, resulting in blockage or low cooling water flow	Blow the cooling pipe with compressed air to clear the blockage
	The electrode holder fails to clamp the tungsten electrode	Replace the electrode holder or electrode cap
Water Leakage	The sealing ring is aged	Replace the sealing ring
	The water pipe joint is damaged or not fastened	Reconnect the water pipe and tighten it
	The weld between the welding torch and the water inlet pipe is leaking	Open it to repair the welding
Air leakage	The sealing ring has aged	Replace the sealing ring
	The connecting thread is loose	Tighten it
	The gas inlet pipe joint is damaged or not fastened	Cut off the damaged joint, reconnect and tighten the replaced gas intake pipe or reliably wrap the damaged area
	The gas inlet pipe has been damaged by heat or aging	Replace the gas inlet pipe
Electric leakage	The electrode holder welding handle is wet due to leakage or other reasons	Find the cause of water leakage, and fully dry the electrode holder
	The electrode holder is damaged or the live metal part is exposed	Replace the electrode holder or wrap the exposed electrified metal part with adhesive tape
Poor gas protection	The welding torch is leaking	Eliminate the leakage
	The nozzle diameter is too small	Replace with a nozzle of larger diameter
	The nozzle is damaged or cracked	Replace with a new nozzle
	The gas circuit in the welding torch is blocked	Blow the circuit with compressed air to clear the blockage
	The gas screen has been damaged or lost during	Replace with a new gas screen

	disassembly and assembly	
	The argon gas is impure	Replace with qualified argon gas
	The gas flow is too large or small	Adjust the gas flow properly
Arc is started between the electrode holder and tungsten electrode or welding torch	The electrode holder and tungsten electrode have poor contact, or arc is started when the tungsten electrode contacts the base metal	Replace the electrode holder or repair
	The electrode holder and welding torch have poor contact	Connect the electrode holder and welding torch properly

9. Troubleshooting



Warning! Before arc welding machines are dispatched from the factory, they have already been checked thoroughly. The machine should not be tampered with or altered. Maintenance must be carried out carefully. If any wire becomes loose or is misplaced, it maybe potentially dangerous to user! Only professional maintenance personnel should repair the machine! Ensure the power is disconnected before working on the machine. Always wait 5 minutes after power switch off before removing the panels.

9.1. Common malfunction analysis and solution



The symptoms listed here may be related to the accessories, gas, environmental factors, and power supply you use. Please try to improve the environment and avoid such situations.

Elimination of general problems in MMA

Symptom		Reasons	Troubleshooting
After startup, the fan does not turn or the wire feeding speed is abnormal		The air temperature may be too low or the fan may be damaged	If the temperature is too low, leave the machine to work for a while. The temperature in standby will rise the fan and resume normal operation. If it is still not working, it is necessary to replace the fan.
MMA	Hard to start the arc	Arc hot start current is low Or the hot start time is short	Increase arc start current or arc start time
	Unstable arc or excessive penetration	Arc start current is high Or the arc start time	Reduce arc start current or start time appropriately

	during arc start	is long	
	Cannot start normal arc	The power cord is not connected properly	Connect the power cord
	Welding slag difficult to remove	Low arc force	Increase the arc force
	Hot electrode holder	The rated current of electrode holder is too low	Change the electrode holder with a high current one
	Arc is easily interrupted	Low mains voltage	Use after the mains power is normal
Other faults			Please contact the maintenance personnel of Shenzhen JASIC Technology Co., Ltd.

Elimination of general problems in TIG

Symptom	Reasons	Troubleshooting
No current is output when torch trigger is pressed	Welding circuit is open	Check the welding circuit and reconnect it
No discharge when starting the arc at high frequency after pressing the torch trigger to start the arc	The torch switch is not plugged in	Plug in the torch switch
	The discharge nozzle gap on the discharge plate is too large or the nozzle is completely closed	Adjust the spark gap on the discharge plate (about 1mm)
Rapid tungsten electrode burnout	Welding torch is connected to the wrong polarity	Switch two plug positions
Blackening of solder joints	Welds are not effectively protected and become oxidized	<p>(1) Ensure that the valve of argon cylinder is open and there is enough pressure. Generally, if the cylinder pressure is lower than 0.5 MPa, it must be refilled.</p> <p>(2) Check whether the argon flow rate is normal. You can select the flow rate according to the welding current condition, but too low a flow rate may lead to insufficient shielding gas to cover all weld joints. It is suggested that the argon flow rate be no less than 5L/min, no matter how small the current.</p> <p>(3) Check whether the gas path is leaking,</p>

		<p>or whether the gas purity is too low.</p> <p>(4) Check whether there is strong ambient air flow in the environment.</p>
<p>Hard to start arc Arc is easily interrupted</p>	<p>Poor quality or serious oxidation of the tungsten electrode</p>	<p>(1) Replace the tungsten grade with better quality.</p> <p>(2) Grind off the tungsten oxide layer.</p> <p>(3) Increase the post-flow delay time to avoid tungsten oxidation.</p> <p>(4) Adjust the spark gap on the discharge plate (about 1mm)</p>
<p>Unstable current when welding</p>	<p>The voltage of the power grid fluctuates seriously or poor contact with the power grid. Serious interference from other electrical equipment.</p>	<p>(1) Check whether the power grid is normal and connect the power connector.</p> <p>(2) Use different power cords to connect equipment that could seriously interfere with welder.</p>
<p>Other faults</p>		<p>Please contact the maintenance personnel of Shenzhen JASIC Technology Co., Ltd.</p>

9.2. Alarms and solutions

Error code	Category	Possible cause	Countermeasure
E10	Overcurrent protection	Continuously output the maximum capacity current of welder	Restart the welder. If overcurrent protection alarm is still active, contact the after-sales department.
E31	Undervoltage protection	Input network voltage is too low	Turn off the machine and restart it. If this the alarm cannot be eliminated and the grid voltage remains too low, check the power grid voltage and wait for the grid to be normal before welding. If the grid voltage is normal and the alarm persists, contact professional maintenance personnel.
E32	Overvoltage protection	Input network voltage is too high	Turn off the machine and restart it. If the alarm cannot be eliminated and the grid voltage remains too high, check the power grid voltage and wait for the grid to be normal before welding. If the grid voltage is normal and the alarm persists, contact professional maintenance personnel.
E34	Undervoltage protection	Undervoltage in driver	Turn off the machine and restart it. If this phenomenon cannot be eliminated, contact professional maintenance personnel.
E60	Overheat protection	Output rectifier diode temperature is too high	Do not turn off the machine. Wait for a while, and then continue welding after the indicator goes out.
E61	Overheat protection	Inverter IGBT temperature is too high	Do not turn off the machine. Wait for a while, and then continue welding after the indicator goes out.
	Abnormal VRD	VRD voltage is too high or low	Turn off the machine and restart it. If the alarm cannot be eliminated, contact professional maintenance personnel.

Note! After applying the above countermeasures, the alarm still cannot be lifted or reappears after lifting. Please contact professional maintenance personnel.

10. Packaging, transportation, storage and waste disposal

10.1. Transportation requirements

In the process of handling the equipment, it should be handled with care, and should not be dropped or severely impacted. Avoid moisture and rain during transportation.

10.2. Storage conditions

Storage temperature: -25 °C ~ + 50 °C

Storage humidity: relative humidity ≤ 90%

Storage period: 12 months

Storage site: indoors with no corrosive gas and air circulation

10.3. Waste disposal

Disposal

The equipment is manufactured with materials, which do not contain any toxic or poisonous materials dangerous to the operator.

When the equipment is scrapped, it should be dismantled separating components according to the type of materials.

Do not dispose of the equipment with normal waste. The European Directive 2002/96/EC on Waste Electrical and Electronic Equipment states the electrical equipment that has reached its end of life must be collected separately and returned to an environmentally compatible recycling facility.

In order to comply with WEEE regulations in your country you should contact your supplier.

RoHS Compliance Declaration

We herewith confirm, that the above mentioned product does not contain any of the restricted substances as listed in EU Directive 2011/65/EC in concentrations above the limits as specified therein.

Disclaimer: Please note that this confirmation is given to the best of our present knowledge and belief. Nothing herein represents and/or may be interpreted as warranty within the meaning of the applicable warranty law.

Appendix 1: Wiring diagram of TIG200P PFC/TIG200PFC

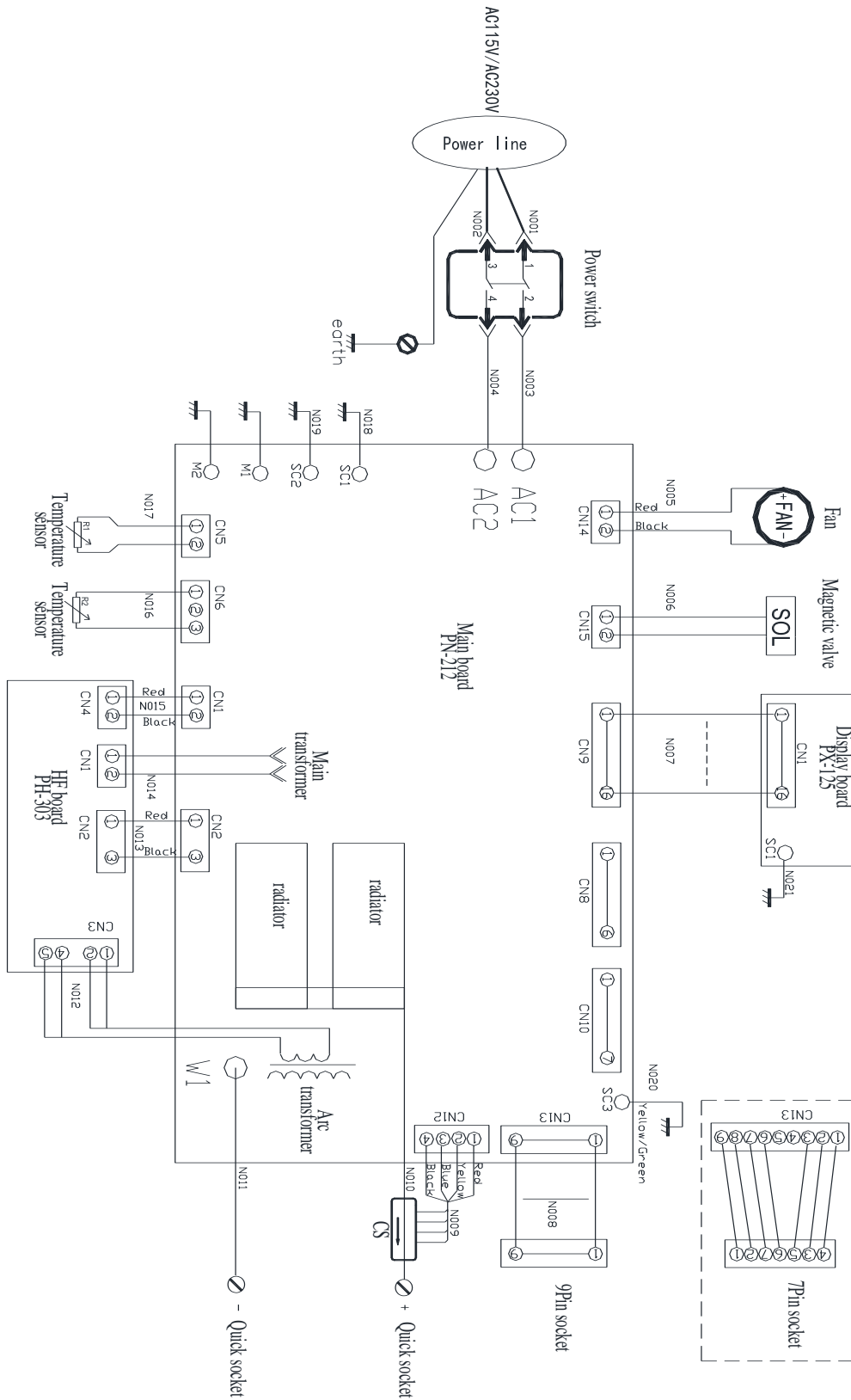

Appendix 2: Wiring diagram of TIG200P/TIG200

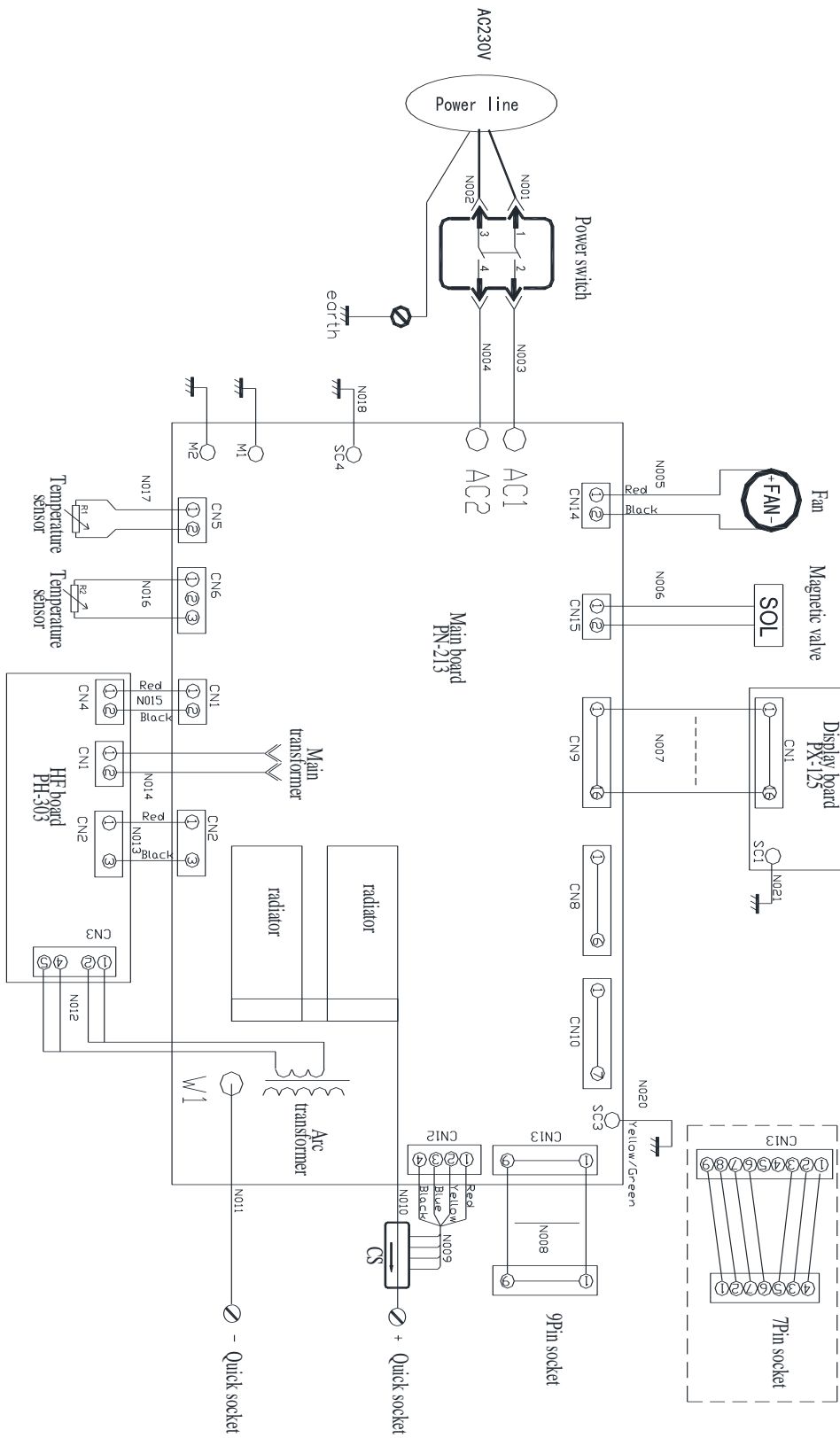

Appendix 3: List of common spare parts

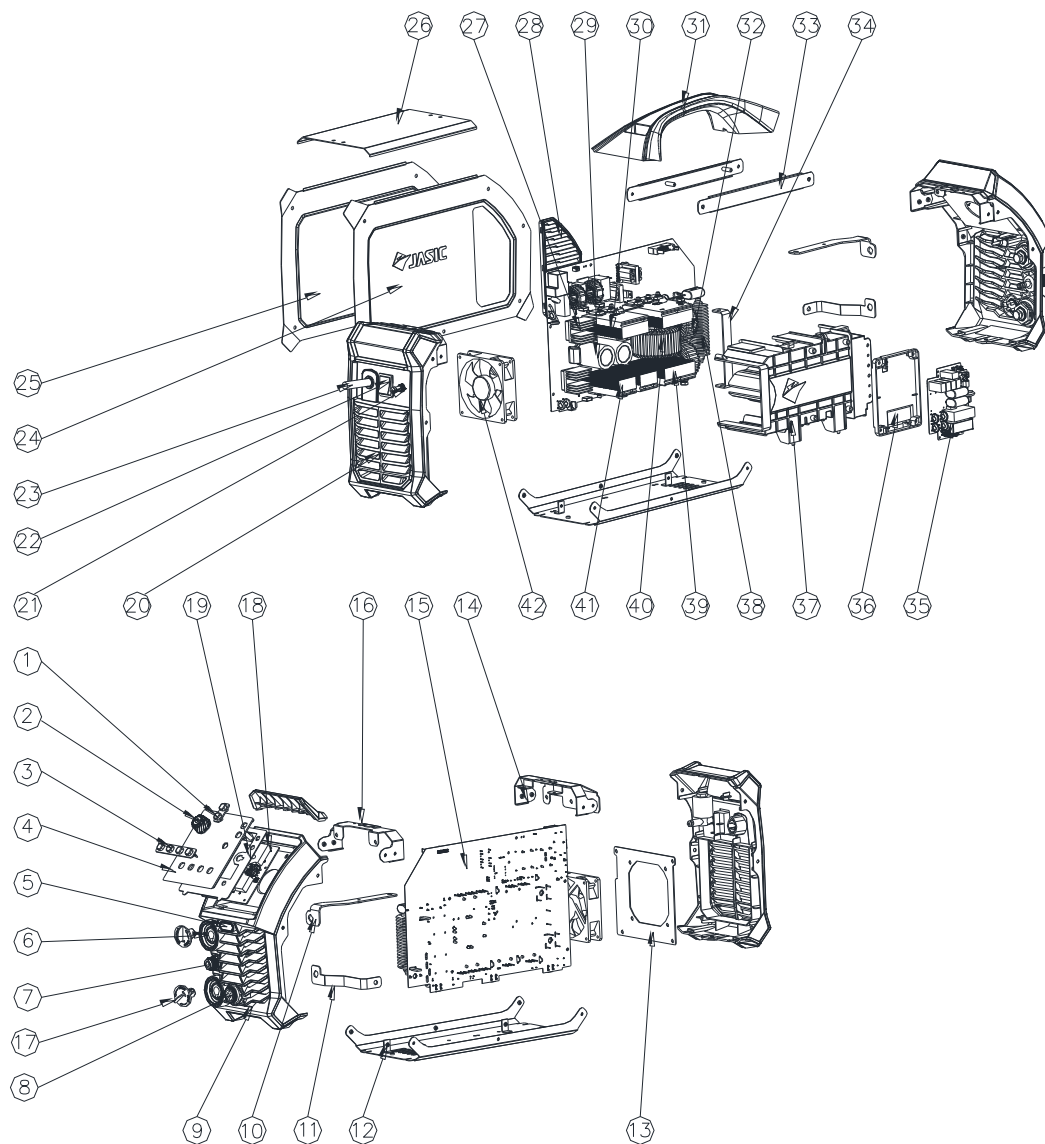

1.TIG200/TIG200P

SN	Material code	Name	Quantity	SN	Material code	Name	Quantity
1	51000375	Silicon button	1	21	51000022	Solenoid Valve (plus)	1
2	10083484	Knob	1		10056884	Solenoid Valve (standard)	
3	51000648	Silicon button	1	22	10071118	Power switch	1
4	10083917	HD digital panel sticker (TIG200)	1	23	51000485	Power cord	1
	10083915	HD digital panel sticker (TIG200P)	1	24	10083651	Right cover	1
5	10083487	Plug	1	25	10083650	Left cover	1
6	10021855	Fast socket	2	26	10083649	Upper cover (plus)	1
7	51002140	Air outlet (standard)	1		51002017	Upper cover (standard)	1
	10016391	Quick connector (plus)	1	27	10050418	Rectifier bridge radiator	2
8	10041400	9-pin aviation socket (plus)	1				
	51001819	7-pin aviation socket (standard)		28	10083671	Louver	1
9	10083816	Front panel (plus)	1	29	10069289	Electrolytic capacitor	2
	51002121	Front panel (standard)		30	10083629	IGBT heat sink	1
10	10083812	Output aluminum connector	1	31	10083690	Handle	1
11	10083810	Output copper connector	1	32	N/A	N/A (Standard)	N/A
12	10083648	Chassis (plus)	1		10075625	Output reactor	2
	51002020	Chassis (TIG200P standard)		33	10083655	Beam	2
	51002021	Chassis (TIG200 standard)		34	10083638	Aluminum connector	1
13	10083646	Fan mounting plate	1	35	51000542	HF PCB board	1

14	10083654	Rear panel bracket	1	36	10083769	HF packaging board	1
15	51000583	Main board PCB (plus)	1	37	10083770	Wind shield	1
	51001868	Main board PCB (standard)	1				
16	10083653	Front panel bracket	1	38	51001879	Pilot arc coil (standard)	1
17	N/A	N/A (Standard)	N/A		51000715	Pilot arc coil (plus)	1
	10083486	Fast socket plug (plus)	2				
18	51000631	Display PCB board (TIG200P)	1	39	10083628	Diode heat sink	2
	51000630	Display PCB board (TIG200)		40	10083636	Main transformer	1
19	10083807	Display iron plate	1	41	10083625	IGBT heat sink	2
20	10083670	Rear panel	1	42	10056858	Fan	1

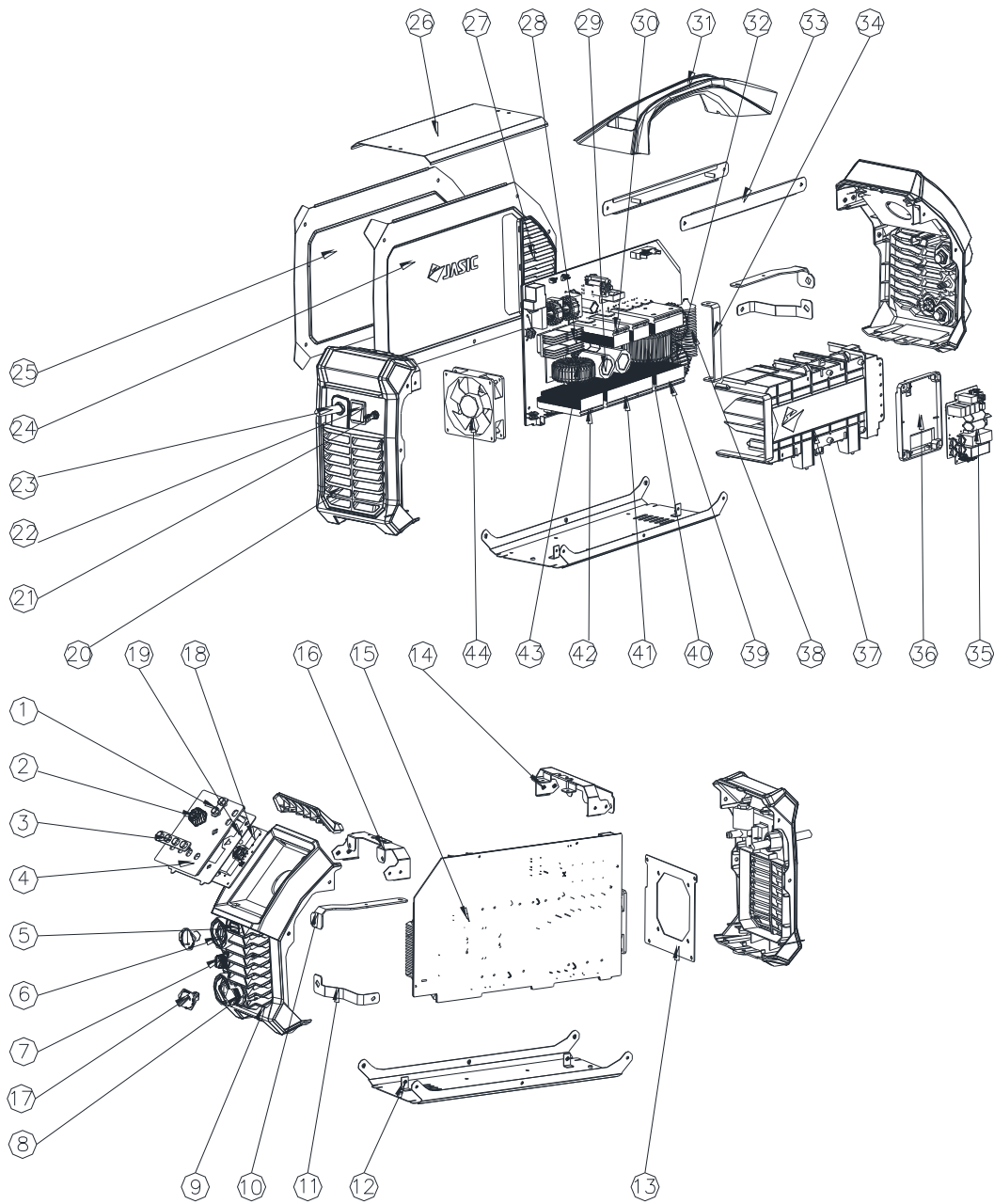

2.TIG200 PFC/TIG200P PFC

SN	Material code	Name	Quantity	SN	Material code	Name	Quantity
1	51000375	Silicon button	1	22	10071118	Power switch	1
2	10083484	Knob	1	23	51001928	Power cord	1
3	51000648	Silicon button	1	24	10083933	Right cover	1
4	10083940	HD digital panel sticker (TIG200P PFC)	1	25	10083930	Left cover	1
	10083916	HD digital panel sticker (TIG200 PFC)	1	26	10083805	Upper cover (plus)	1
5	10083487	Plug	1		51002016	Upper cover (standard)	
6	10021855	Fast socket	2	27	10083671	Louver	1
7	51002140	Air outlet (standard)	1	28	10050418	Rectifier bridge radiator	2
	10016391	Quick connector (plus)	1	29	10069289	Electrolytic capacitor	2
8	10041400	9-pin aviation socket (plus)	1	30	10083625	IGBT heat sink	2
	51001819	7-pin aviation socket (standard)	1				
9	10083816	Front panel (plus)	1	31	10083768	Handle	1
	51002121	Front panel (standard)	1	32	10075625	Output reactor (plus)	2
10	10083812	Output aluminum connector	1		N/A	N/A (Standard)	N/A
11	10083811	Output copper connector	1	33	10083808	Beam	2
12	10083806	Chassis (plus)	1	34	10083638	Aluminum connector	1
	51002014	Chassis (TIG200PPFC standard)		35	51000542	HF PCB board	1
	51002015	Chassis		36	10083769	HF packaging	1

		(TIG200PFC standard)				board	
13	10083646	Fan mounting plate	1	37	10083689	Wind shield	1
14	10083654	Rear panel bracket	1	38	51000715	Pilot arc coil (plus)	1
15	51000547	Main board PCB (plus)	1		51001879	Pilot arc coil (standard)	
		51001872	Main board PCB (standard)	1	39	10083628	Diode heat sink
16	10083653	Front panel bracket	1				
17	10083486	Fast socket plug (plus)	2	40	10083635	Main transformer	1
	N/A	N/A(Standard)	N/A	41	10083629	IGBT heat sink	1
18	51000631	Display PCB board (TIG200P PFC)	1	42	51000456	PCB inductor	1
	51000630	Display PCB board (TIG200 PFC)					
19	10083807	Display iron plate	1	43	10083626	PFC IGBT heat sink	1
20	10083670	Rear panel	1	44	10056858	Fan	1
21	51000022	Solenoid Valve (plus)	1				
	10056884	Solenoid Valve (standard)					

 **JASIC®** | Passionate About Your Welding

SHENZHEN JASIC TECHNOLOGY CO., LTD.

Address: No. 3, Qinglan 1st Road, Pingshan District, Shenzhen, Guangdong, China

Postcode: 518118

Tel: +86 (0755) 8670 6250

Fax: +86 (0755) 2736 4108

Website: www.jasitech.com

E-mail: sales@jasitech.com

 @JASICTechWelding

 JASIC Technology Co., Ltd.

 @jasitech_official